

# ITT

## Residential Water Systems

# Goulds Pumps

JS+ Shallow Well Jet Pumps  
1/2, 3/4, 1 and 1 1/2 HP  
J5S, J5SH, J7S, J10S, J15S



Goulds Pumps is a brand of ITT Residential and Commercial Water.

[www.goulds.com](http://www.goulds.com)

*Engineered for life*

## FEATURES

■ **Compact:** Design has an integral shallow well adapter built into the casing, which eliminates the need for a separate shallow well adapter.

■ **Serviceable:**

- Back pullout design allows disassembly of pump for service without disturbing piping.
- Two compartment motor for easy access to motor wiring and replaceable components.
- Nozzle clean out plug in pump case.
- Corrosion resistant, engineered plastic tubing and fittings are easily removed for cleaning. Premium O-ring design fittings need only be hand tight to seal.

■ **Impeller:** F.D.A. compliant, glass filled Noryl® is corrosion and abrasion resistant.

■ **Diffuser (Guidevane):** Bolt down diffuser provides positive alignment with impeller. Diffuser has stainless wear ring for extended performance in abrasive conditions. F.D.A. compliant, injection molded, food grade, glass filled Lexan® for durability and abrasion resistance.

■ **Tubing and Fittings:** F.D.A. compliant engineered plastic is corrosion and U.V. resistant.

■ **Powered for Continuous Operation:** Pump ratings are within the motor manufacturer's recommended working limits. Can be operated continuously without damage.

■ **Corrosion Resistant:** Electro-coat paint process is applied inside and out, then baked on.

■ **Protected Mechanical Seal:** Special diaphragm design retains water in the casing at all times to ensure the mechanical seal can never run dry.

■ **Excellent Air Handling Ability:** After initial priming the pump has the ability to re-prime itself even when air gets into the system. Pumping resumes once the water level rises above the foot valve.

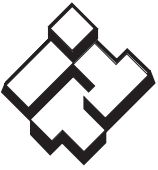

# ITT

## GOULDS PUMPS Residential Water Systems

### APPLICATIONS

Specifically designed for:

- Homes
- Cottages
- Booster service

### SPECIFICATIONS

#### Pump:

- Pipe connections:  
1 1/4" NPT suction  
1" NPT discharge.
- Pressure switch:  
AS4FX preset (30-50 PSI).

#### Motor:

- NEMA standard.
- 60 Hz.
- 1/2 – 1 1/2 HP, 115/230 V capacitor start.
- Single phase.
- 3500 RPM.
- Built-in overload with automatic reset.
- Stainless steel shaft.
- Rotation: clockwise when viewed from motor end.
- UL778 listed.

Maximum temperature: 140°F.

### SYSTEM COMPONENTS

■ **Basic Pump Unit:** Includes pump with integral shallow well jet (nozzle and venturi), motor, pressure switch and tubing.

### AGENCY LISTINGS



Goolds Pumps is ISO 9001 Registered.

### MODEL INFORMATION

CSA Listed Order No.	U.L. Listed (Indoor use) <sup>①</sup> Order No.	HP
J5S	J5SUL	1/2
J5SH	J5SHUL	1/2
J7S	J7SUL	3/4
J10S	J10SUL	1
J15S	J15SUL	1 1/2

### SHALLOW WELL PERFORMANCE RATINGS

HP/Model	1/2 HP – J5S					1/2 HP – J5SH					3/4 HP – J7S					1 HP – J10S					1 1/2 HP – J15S					
Nozzle	AN017					AN019					AN018					AN018					AN022					
Venturi	AD3332					AD3328					AD3336					AD3339					AD3342					
	Discharge Pressure – PSI					Discharge Pressure – PSI					Discharge Pressure – PSI					Discharge Pressure – PSI					Discharge Pressure – PSI					
Total Suction Lift (feet)	20	30	40	50	Max. Shut off (PSI)	20	30	40	50	60	Max. Shut off (PSI)	30	40	50	60	Max. Shut off (PSI)	30	40	50	60	Max. Shut off (PSI)	30	40	50	60	Max. Shut off (PSI)
	Gallons per minute					Gallons per minute						Gallons per minute					Gallons per minute									
5	17.5	16.5	10.2	5.0	63	11.5	11.3	11.0	7.7	4.8	83	21.3	18.3	12.5	6.6	70	24.8	24.4	16.6	9.9	74	26.6	26.3	25.0	15.6	80
10	15.7	14.4	9.2	4.3	61	10.3	10.0	9.6	7.0	4.2	81	18.8	17.3	11.3	5.0	68	22.9	22.2	15.8	8.6	72	24.7	24.3	22.6	13.9	77
15	13.7	12.5	8.0	3.6	59	8.8	8.6	8.3	6.3	3.7	79	16.4	15.5	9.6	3.7	66	19.8	19.5	13.8	6.9	70	21.6	21.5	20.4	12.9	75
20	11.5	10.4	7.1	2.3	57	7.0	7.0	6.8	5.8	3.2	76	13.6	13.2	8.3	2.0	63	16.6	16.6	12.2	5.6	67	18.1	18.0	17.6	12.0	73
25	8.7	8.6	6.2	1.3	54	5.3	5.2	5.2	5.0	2.8	73	10.0	9.9	6.4	1.0	59	12.5	12.4	10.4	3.6	65	14.0	14.0	14.0	10.1	71

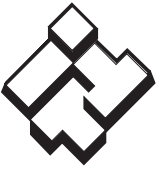

# ITT

## GOULDS PUMPS Residential Water Systems

### COMPONENTS

Item No.	Description
1	Mechanical seal
2	Pressure switch
3	Casing
4	Impeller
5	Diffuser (Guidevane)
6	Diaphragm
7	Stainless steel shaft
8	Nozzle clean-out plug
9	Motor adapter
10	Motor
11	Nozzle
12	Venturi (diffuser)

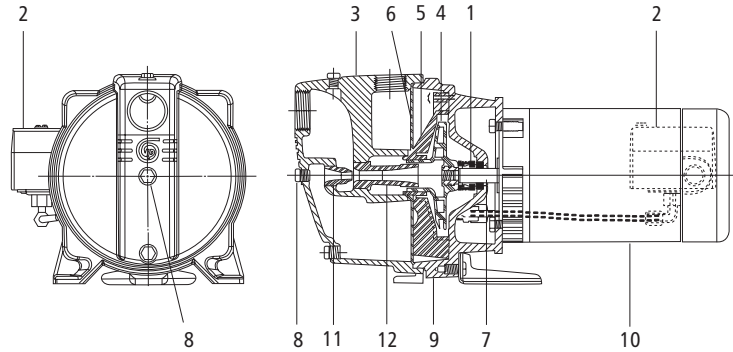

### DIMENSIONS AND WEIGHTS

Model	J5S	J5SH	J7S	J10S	J15S
Wt. (lbs.)	43	43	47	50	60
Length	17 $\frac{1}{4}$	17 $\frac{1}{4}$	18 $\frac{1}{4}$	18 $\frac{3}{4}$	19 $\frac{1}{4}$
Width	9 $\frac{7}{8}$				
Height	8 $\frac{3}{4}$				
HP	$\frac{1}{2}$	$\frac{1}{2}$	$\frac{3}{4}$	1	1 $\frac{1}{2}$
"L" Max.	8 $\frac{1}{2}$	8 $\frac{1}{2}$	9 $\frac{1}{2}$	10	10 $\frac{1}{2}$

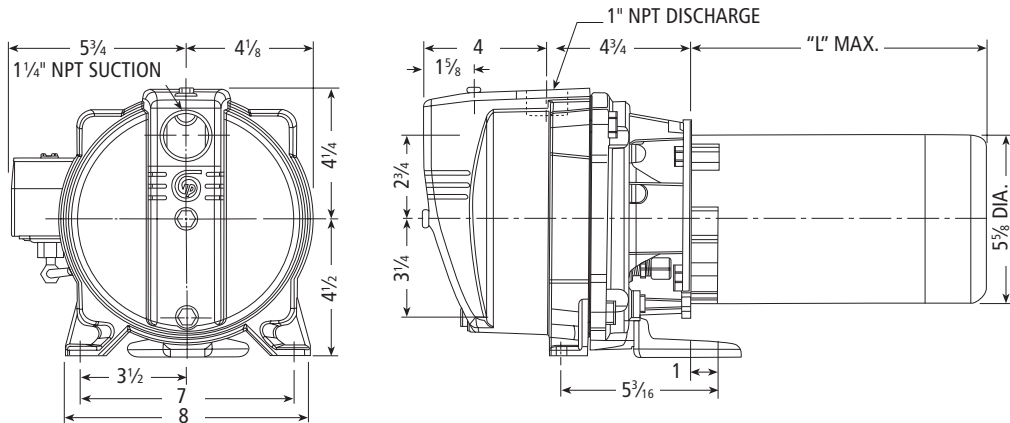

(All dimensions are in inches and weights in lbs. Do not use for construction purposes.)



**ITT**

**Residential Water Systems**



Goulds Pumps and the ITT Engineered Blocks Symbol are registered trademarks and tradenames of ITT Corporation.

Noryl® and Lexan® are trademarks of GE Plastic.

SPECIFICATIONS ARE SUBJECT TO CHANGE WITHOUT NOTICE.

**BJS+ January, 2007**

© 2007 ITT Corporation

*Engineered for life*