

ITT

Residential Water Systems

Goulds Pumps

J+ Convertible Jet Pumps
1/2, 3/4, 1 and 1 1/2 HP - 60 Hz

J5, J7, J10 and J15

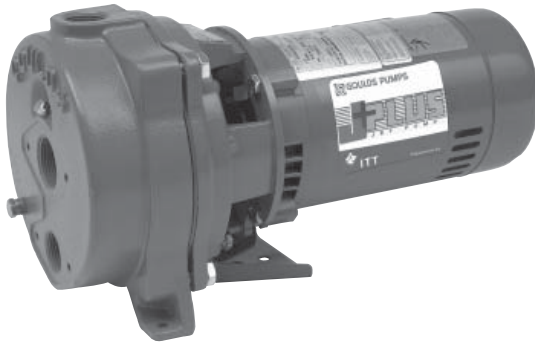

Goulds Pumps is a brand of ITT
Residential and Commercial Water.

www.goulds.com

Engineered for life

FEATURES

- **Convertible:** May be used on shallow or deep well applications using appropriate Goulds Pumps fittings.
- **Serviceable:**
 - Back pullout design for service without disturbing piping.
 - Two compartment motor for access to wiring and replaceable components.
 - Nozzle clean out plug in shallow well adapter.
 - Corrosion resistant, plastic tubing and fittings are easily removed for cleaning. Premium O-ring design fittings need only be hand tight to seal.
- **Impeller:** F.D.A. compliant, glass filled Noryl®. Corrosion and abrasion resistant.
- **Diffuser (Guidevane):** Bolt down Lexan® diffuser has stainless wear ring for extended performance in abrasive conditions.
- **Powered for Continuous Operation:** Pump ratings are within the motor manufacturer's recommended working limits. Can be operated continuously without damage.
- **Corrosion Resistant:** Electro-coat paint is baked on.
- **Protected Mechanical Seal:** Diaphragm retains water in the casing to ensure the mechanical seal can never run dry.
- **Excellent Air Handling Ability:** After initial priming the pump has the ability to re-prime itself.

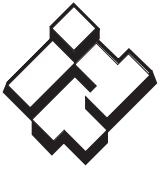

ITT

GOULDS PUMPS Residential Water Systems

APPLICATIONS

Specifically designed for:

- Homes
- Farms
- Cottages
- Booster service

SPECIFICATIONS

Pump:

- Pipe connections:
1 1/4" NPT suction
1" NPT discharge
1" NPT drive (pressure).
- Pressure switch: AS4FX preset at 30-50 PSI.

Motor:

- NEMA standard.
- 60 Hz.
- 1/2 – 1 1/2 HP, 115/230 V capacitor start.
- Single phase.
- 3500 RPM.
- Built-in overload with automatic reset.
- Stainless steel shaft.
- Rotation: clockwise when viewed from motor end.
- UL778 listed.

Maximum temperature: 140°F

SYSTEM COMPONENTS

- **Basic Pump Unit:** Includes pump and motor, pressure gauge and bushing, pressure switch with tubing and fittings.

NOTE: THE TUBING COMES CONNECTED FOR SHALLOW WELL USE. A DEEP WELL SET UP REQUIRES A JDW FITTINGS PACKAGE OR AN AV22 KIT.

Both include additional fittings and a 24" tubing to connect to a pressure control valve.

ADDITIONAL COMPONENTS REQUIRED

- **Shallow Well Package:** Includes shallow well adapter, nozzle, venturi (diffuser), gasket, bolts and pipe plugs OR
- **Deep Well Package:** Choose either a twin pipe or packer style.
 - Twin pipe includes jet body, nozzle, venturi (diffuser) and foot valve.
 - Packer includes packer body, nozzle, venturi (diffuser), and built-in check valve.
- NOTE:** Packer systems also require a packer adapter on the wellhead.
- Deep well systems require a pressure control valve.
 - NOTE: YOU MUST HAVE A JDW OR AV22 KIT TO MAKE THE PRESSURE SWITCH CONNECTION.**
- Pressure tank required on all systems.

AGENCY LISTINGS



Goulds Pumps is ISO 9001 Registered.

MODEL INFORMATION

CSA Listed Order No.	U.L. Listed (Indoor use)① Order No.	HP
J5	J5UL	1/2
J7	J7UL	3/4
J10	J10NUL	1
J15	J15UL	1 1/2

SHALLOW WELL PERFORMANCE RATINGS

HP/Model	1/2 HP – J5					1/2 HP – J5					3/4 HP – J7					1 HP – J10					1 1/2 HP – J15																													
Shallow Well Package	FH5					FH5H (High Pressure Model)					FH7					FH10					FH15																													
Adapter	4K62																																																	
Nozzle	AN017					AN019					AN018					AN018					AN022																													
Venturi	AD3731					AD3528					AD3536					AD3538					AD3542																													
Total Suction Lift (feet)	Discharge Pressure – PSI										Discharge Pressure – PSI										Discharge Pressure – PSI										Discharge Pressure – PSI										Discharge Pressure – PSI									
					Max. Shut off (PSI)					Max. Shut off (PSI)					Max. Shut off (PSI)					Max. Shut off (PSI)					Max. Shut off (PSI)					Max. Shut off (PSI)																				
	Gallons per minute					Gallons per minute					Gallons per minute					Gallons per minute					Gallons per minute					Gallons per minute																								
5	17.5	16.5	10.2	5.0	63	11.5	11.3	11.0	7.7	4.8	83	21.3	18.3	12.5	6.6	70	24.8	24.4	16.6	9.9	74	26.6	26.3	25.0	15.6	80																								
10	15.7	14.4	9.2	4.3	61	10.3	10.0	9.6	7.0	4.2	81	18.8	17.3	11.3	5.0	68	22.9	22.2	15.8	8.6	72	24.7	24.3	22.6	13.9	77																								
15	13.7	12.5	8.0	3.6	59	8.8	8.6	8.3	6.3	3.7	79	16.4	15.5	9.6	3.7	66	19.8	19.5	13.8	6.9	70	21.6	21.5	20.4	12.9	75																								
20	11.5	10.4	7.1	2.3	57	7.0	7.0	6.8	5.8	3.2	76	13.6	13.2	8.3	2.0	63	16.6	16.6	12.2	5.6	67	18.1	18.0	17.6	12.0	73																								
25	8.7	8.6	6.2	1.3	54	5.3	5.2	5.2	5.0	2.8	73	10.0	9.9	6.4	1.0	59	12.5	12.4	10.4	3.6	65	14.0	14.0	14.0	10.1	71																								

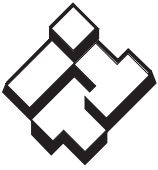

ITT

GOULDS PUMPS Residential Water Systems

TWIN PIPE PERFORMANCE RATINGS

HP/Model		½ HP – J5				¾ HP – J7				1 HP – J10				1½ HP – J15				
Well Casing min. I.D.	Pipe	4		4½		4		4½		4		4½		4½				
Pressure	Pipe Size (in.)	1		1¼		1		1¼		1		1¼		1¼				
Suction	Pipe Size (in.)	1¼		1½		1¼		1½		1¼		1½		1½				
① Jet Assembly Package		FT4-13	FT4-31	FT4-08	FT5-14	FT4-14	FT4-34	FT4-18	FT5-47	FT5-48	FT4-44	FT4-43	FT4-18	FT5-49	FT5-11	FT5-12	FT5-11	
Jet Body (only)		AT4		AT5		AT4		AT5		AT4		AT5		AT5				
Nozzle		AN017	AN016	AN015	AN018	AN017	AN016	AN016	AN018	AN017	AN017	AN016	AN016	AN019	AN018	AN019	AN018	
Venturi		AD726	AD723	AD720	AD724	AD729	AD725	AD722	AD730	AD725	AD730	AD727	AD722	AD732	AD727	AD734	AD727	
Control Valve Setting (PSI)		30	30	30	30	28	29	30	28	30	31	33	35	30	32	35	40	
	Feet	Gallons Per Minute (GPM) 30-50 PSI Pressure Switch Setting																
Depth to Jet Assembly (based on submergence of 5 feet)	30	13.0	11.0			15.8			16.6		17.0			19.3			21.2	
	40	11.8	9.0			15.7			16.0		16.6			18.0			20.0	
	50		7.6		6.9	13.2			15.0		14.4			16.0			16.1	
	60		7.0	5.2	6.4	10.2			13.0		11.5	11.2		14.3			15.0	
	70			4.7	5.6		8.2		11.0	10.0		9.3		12.6			14.0	11.2
	80			3.8	4.8		6.5			8.6		7.3	6.2	10.0	10.0		10.6	
	90			3.1	4.1		5.0	5.0		7.3			6.1		8.7		9.0	
	100							4.4		6.0			5.4		7.0		7.6	
	110								3.5	5.0			4.5		5.7		6.2	
	120														4.5		5.2	
	130																4.0	
	140																2.8	
	150																1.5	
	160																	
170																		

① Jet assembly package includes: jet body, nozzle, Venturi and foot valve.

PACKER SYSTEM PERFORMANCE RATINGS

HP/Model		½ HP – J5				¾ HP – J7				1 HP – J10				1½ HP – J15				
Well Casing	Pipe	2		3		2		3		2		3		3				
Suction	Pipe Size (in.)	1¼		1½		1¼		1½		1¼		1½		1½				
① Jet Assembly Package		FP2-13	FP2-31	FP2-08	FP3-36	FP3-24	FP2-40	FP2-47	FP3-53	FP3-54	FP2-48	FP2-43	FP3-55	FP3-14	FP3-16	FP3-18	FP3-21	FP3-24
Jet Body (only)		AP2		AP3		AP2		AP3		AP2		AP3		AP3				
Nozzle		AN017	AN016	AN015	AN021	AN018	AN015	AN015	AN018	AN017	AN016	AN016	AN019	AN018	AN019	AN021	AN023	AN018
Venturi		AD726	AD723	AD720	AD730	AD724	AD727	AD723	AD730	AD725	AD729	AD725	AD732	AD727	AD735	AD723	AD731	AD724
Control Valve Setting (PSI)		30	30	30	30	30	32	27	30	35	36	28	32	34	34	34	34	39
	Feet	Gallons Per Minute (GPM) 30-50 PSI Pressure Switch Setting																
Depth to Jet Assembly (based on submergence of 5 feet)	30	11.9	9.5		13.1			13.8		16.8		16.7		19.3			24.4	
	40	10.6	7.9		12.6			13.5		16.8		14.6		19.3			23.1	
	50		7.6		10.7	6.9	11.5		15.3		13.5		18.0			20.2		
	60		6.7	4.8	8.8	6.5	9.0	7.8	13.5		11.0	9.2	15.3		16.9	15.0		
	70			4.3	7.3	5.6		7.1	11.5	9.8		9.0	12.7			14.4		
	80			3.5	4.8			5.1		8.6		7.3	10.2	10.3		12.9		
	90							4.3		7.3		5.6		8.8		10.9	10.3	
	100									6.2		4.2		7.2			9.6	7.3
	110									5.0				5.8			8.2	6.5
	120													4.5			6.9	5.8
	130																5.8	5.0
	140																4.7	4.5
	150																3.4	4.0
	160																	3.3
170																	2.8	

① Jet assembly package includes: jet body, Venturi, nozzle, built-in check valve, leather crimps, spacer and fitting.

Important: An offset of 50 feet will result in a decrease of about 25% from ratings as shown.



ITT

Residential Water Systems

COMPONENTS

Item No.	Description
1	Mechanical seal
2	Pressure switch
3	Casing
4	Impeller
5	Diffuser (Guidevane)
6	Diaphragm
7	Stainless steel shaft
8	Nozzle clean-out plug
9	Motor adapter
10	Motor
11	Nozzle
12	Venturi (diffuser)

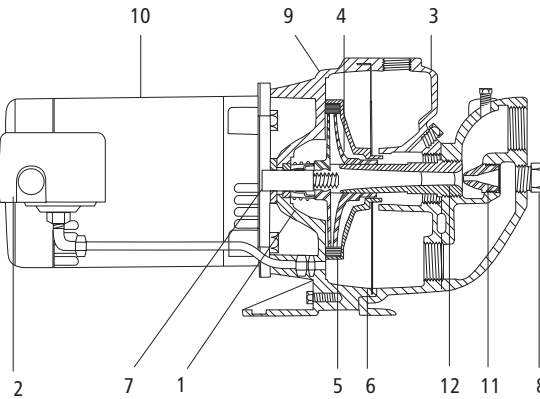

Shallow Well Model

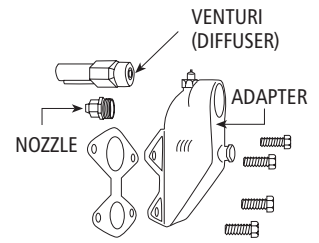

Shallow Well Package

DIMENSIONS AND WEIGHTS

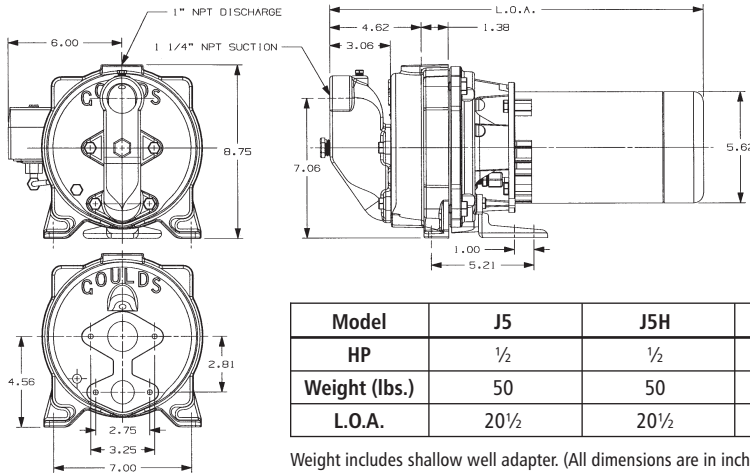

Model	J5	J5H	J7	J10	J15
HP	1/2	1/2	3/4	1	1 1/2
Weight (lbs.)	50	50	55	59	68
L.O.A.	20 1/2	20 1/2	21	21 1/2	24

Weight includes shallow well adapter. (All dimensions are in inches and weights in lbs. Do not use for construction purposes.)



Goolds Pumps and the ITT Engineered Blocks Symbol are registered trademarks and tradenames of ITT Corporation.

Noryl and Lexan are trademarks of GE Plastic.

SPECIFICATIONS ARE SUBJECT TO CHANGE WITHOUT NOTICE.

BJ+ January, 2007

© 2007 ITT Corporation

Engineered for life