



ITT

Ag./Irrigation

Goulds Pumps

Ag-Flo

Close-Coupled/Frame Mounted/
SAE Centrifugal Pumps



Goulds Pumps is a brand of ITT Water Technology, Inc.
- a subsidiary of ITT Industries, Inc.

www.goulds.com

Engineered for life

Goulds Pumps Ag-Flo Series builds on over 150 years of hydraulic and manufacturing expertise to produce the finest pump in the industry. Our line of cast iron close coupled and SAE drive centrifugal pumps are offered with a variety of options to make them suited to almost any irrigation application.

Hydraulic Capabilities

- Flows to 4500 GPM
- Heads to 400 feet
- Temperatures to 250°F
- Pump can withstand pressures to 200 PSI

Typical Applications

- Center pivot irrigation
- Flood irrigation
- Drip irrigation
- Spray irrigation
- General turf irrigation

Features and Benefits

The Ag-Flo has many features that make it suitable for virtually any application:

- Heavy casing wall increases the life of pump components by resisting corrosion and abrasion from sand, silt and other aggressive conditions.
- Bronze wear rings can be removed and replaced to maintain pump efficiency without changing the casing or seal housing.
- Mechanical seal and packing options are available to suit a wide variety of applications.
- SAE option allows liquid ends to be mounted to gas or diesel engines for application where electricity is not readily available.
- Available in cast iron / bronze fitted or all iron.



Product Description

Casing

- Casings with suctions 3" and smaller can be rotated every 90°, casings 4" and larger can be rotated every 45°.
- Thick wall provides maximum abrasion resistance and prevents failure in the event of pressure pulsations.
- Dual volute on larger sizes equalizes axial thrust loads to promote long bearing and shaft life.
- Heavy duty design allows for vertical (suction down) mounting.



Internals

- Shaft sealing can be accomplished with a rotating mechanical seal or optional packed box design.
- PrimeSafe™ option prevents against dry running utilizing a grease-filled gland.
- Available with silicon bronze or cast iron impellers.
- Replaceable wear rings and shaft sleeve affords extended operation of the pump.



Drivers

- Available as close-coupled, frame mounted or SAE drive.
- Close-coupled pumps can be mounted with either TEFC or ODP motors.
- SAE drive pumps have optional splined shaft.



Performance Coverage Curves

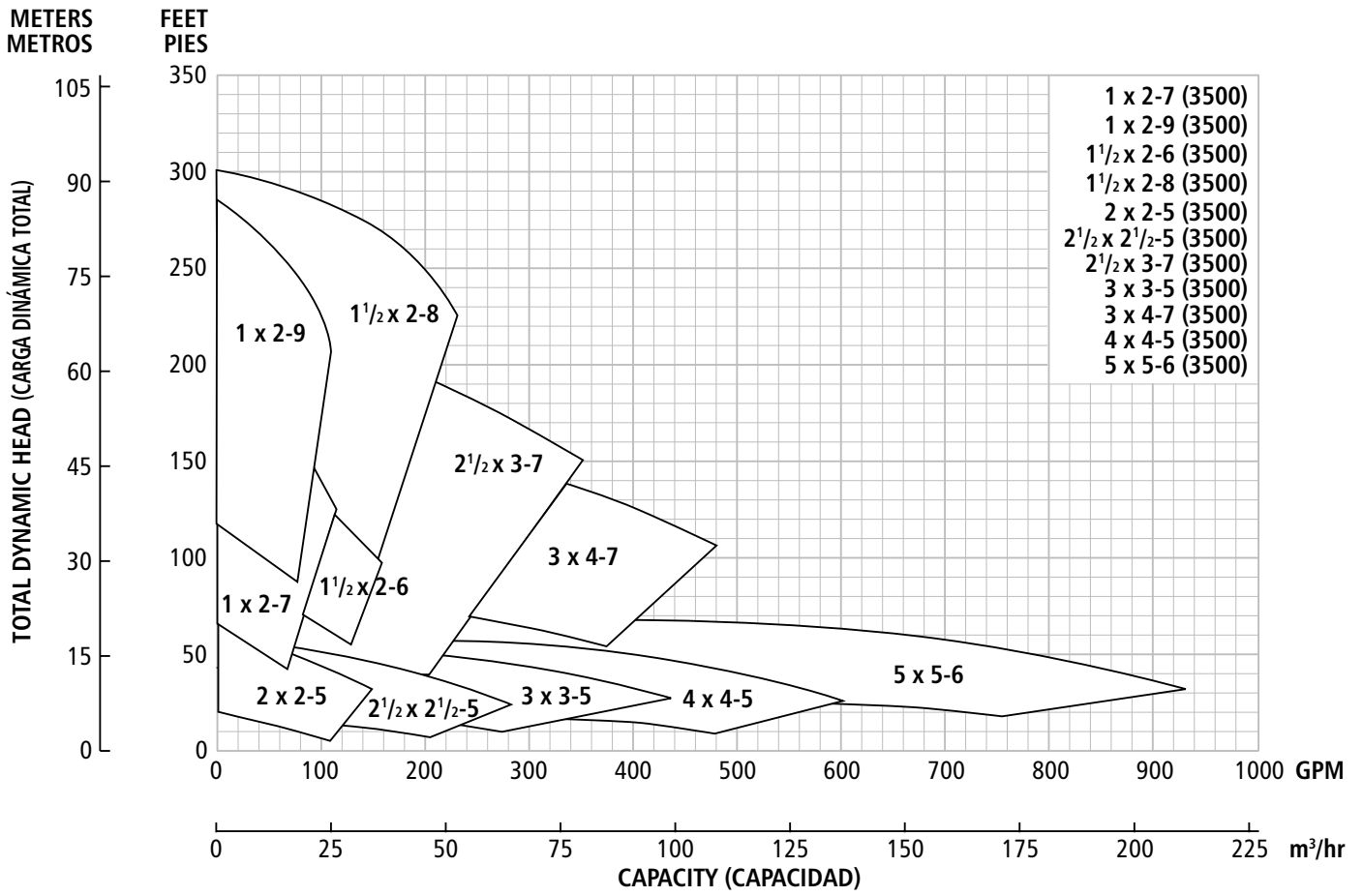

Performance Coverage Curves

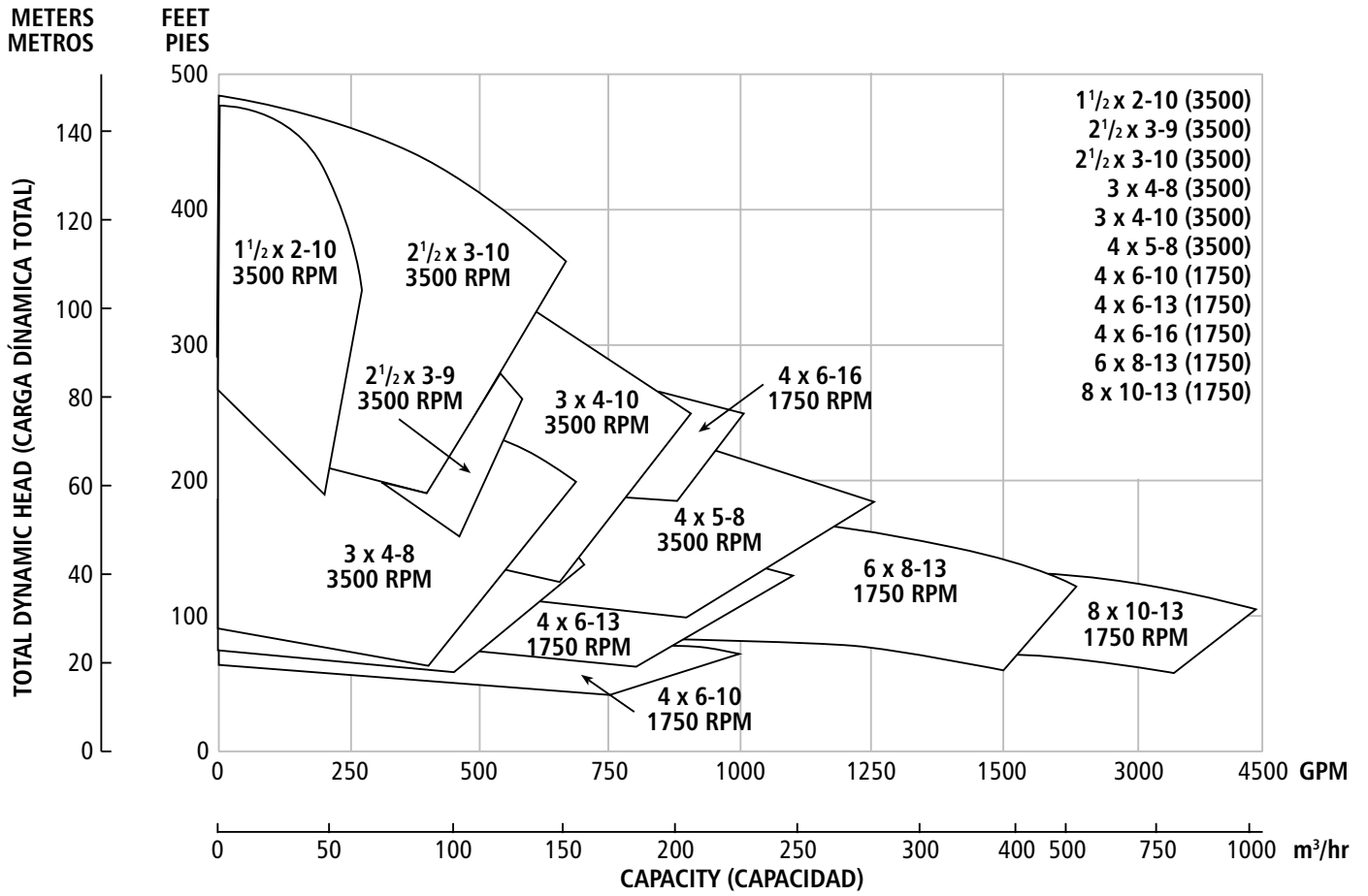

Performance Coverage Curves

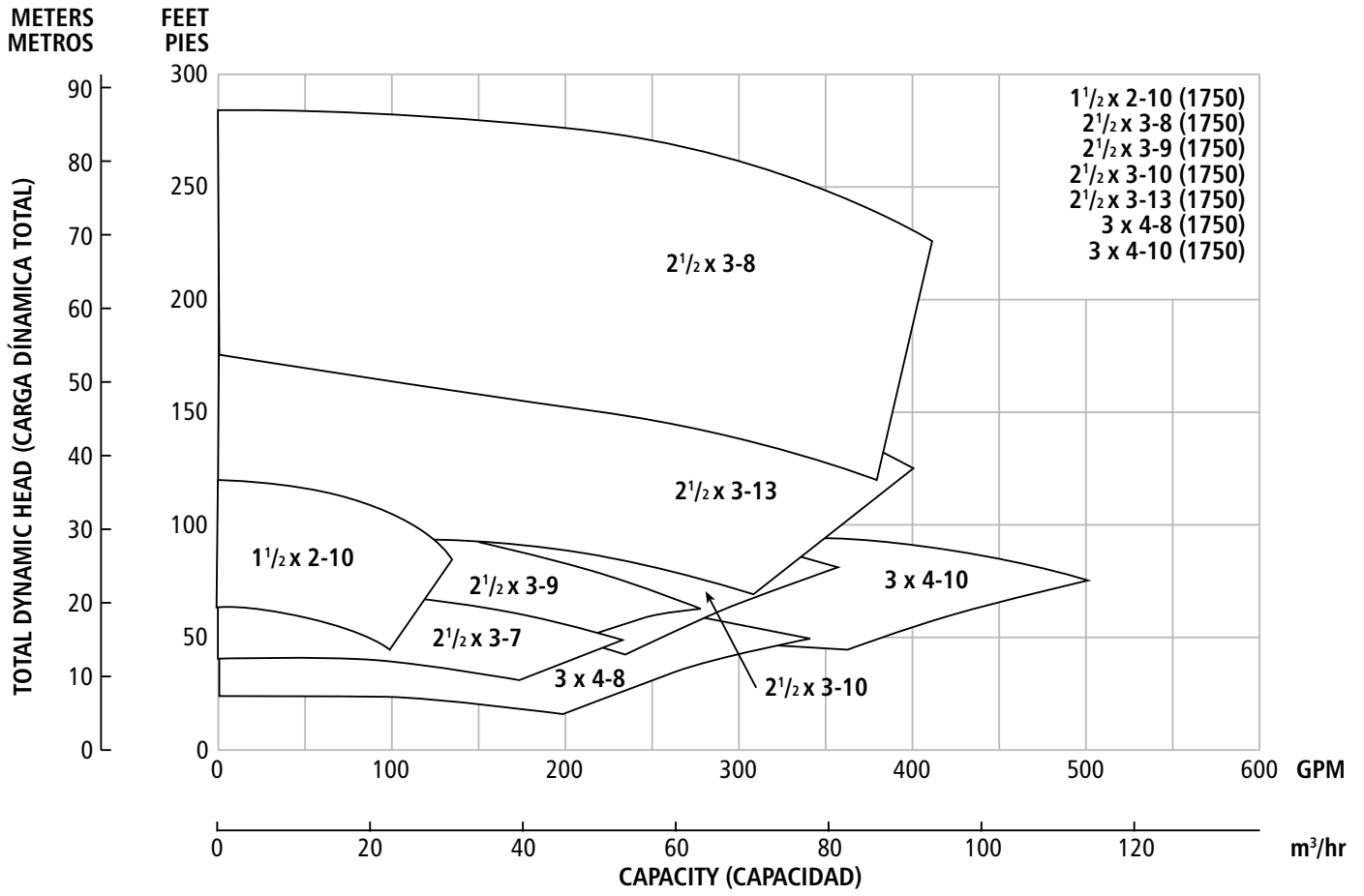

Ag-Flo Close-Coupled Centrifugal Pumps

Open seal housing reduces the seal and housing wear and chance of failure from sand, silt, or debris build up.

The casing is sealed with an o-ring for increased reliability and ease of maintenance.

Stainless Steel shaft sleeve protects the motor shaft and simplifies seal replacements

Close coupled for space savings and simplified maintenance

Replaceable wear rings allow impeller clearances to be maintained to ensure a long life and optimum performance.

Standard NEMA motors are available in either "Open Drip Proof" or "Totally Enclosed Fan Cooled".

Enclosed impeller design maximizes hydraulic performance and efficiency.

Standard mechanical seal is self-lubricating with stainless steel metal parts for high quality corrosion resistant performance.

Back pull – out design allows for pump maintenance and removal of rotating components without the time consuming task of removing pipe connections.

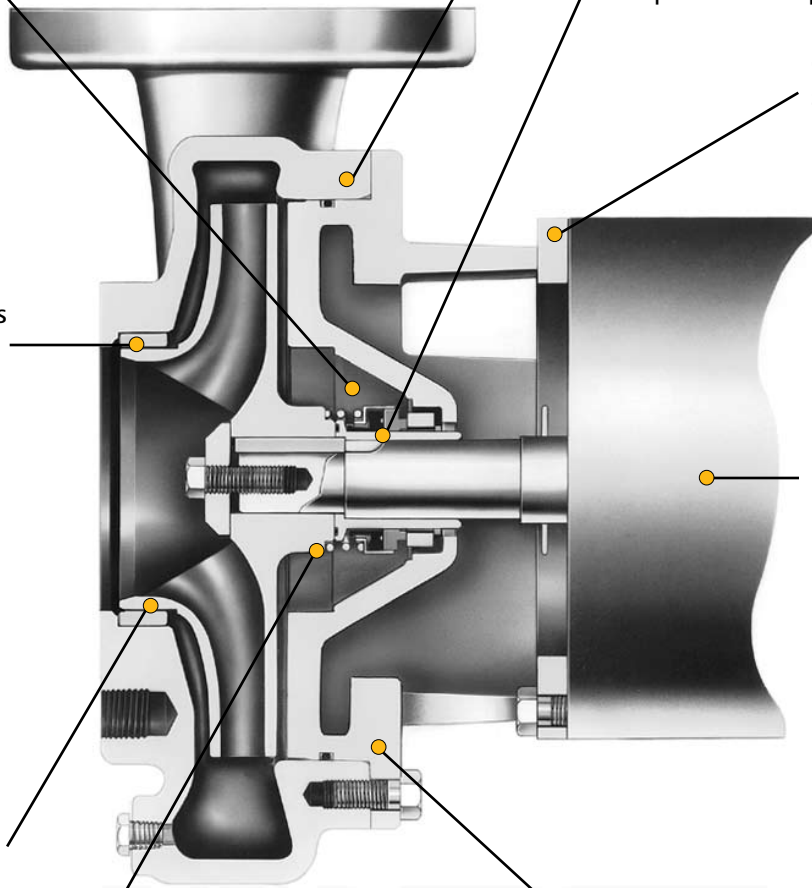

Ag-Flo SAE Drive Centrifugal Pumps

Two piece packing gland allows for replacement of packing without pump disassembly. Teflon impregnated packing is provided as standard. SAE drive pumps can also be provided with a mechanical seal.

Large access openings make packing adjustments simple and safe.

Heavy duty ball bearings designed for minimum L-10 bearing life of 20,000 hours. Zurc type grease fittings are provided to simplify routine maintenance.

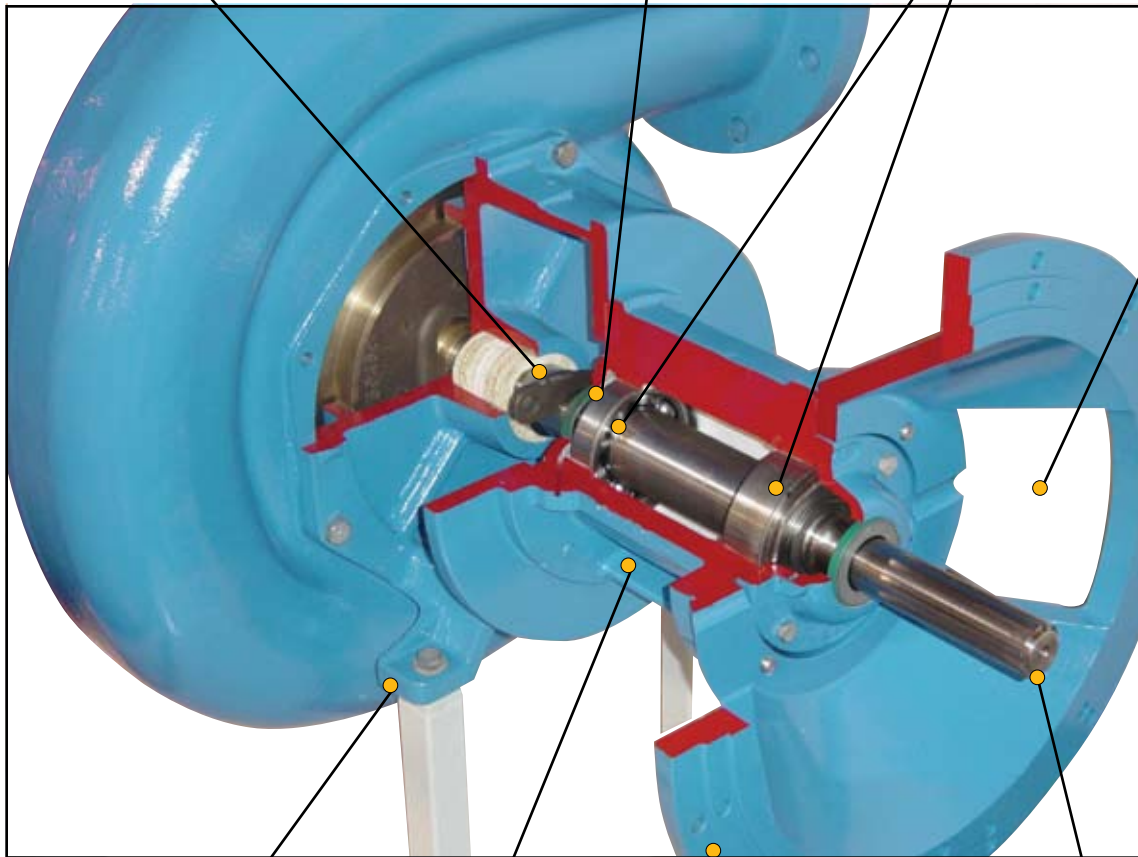

Large access openings in the SAE mounting adapter are provided to enable inspection and/or lubrication of the pump and the coupling. Removable guards (not shown) are provided for safe operation.

Additional casing support foot is provided for larger size pumps to maintain the alignment between the pump end and the engine for increased pump and engine life.

The bearing frame is designed with an integral cast "I" beam to provide a rigid support between the pump and engine to maintain alignment for increased life.

Engine adapters have multiple drillings for increased flexibility for multiple engine sizes.

High strength steel shaft available with either splined or keyed connection.

Ag-Flo Materials of Construction

Component	All Iron (FE)		Bronze-Fitted (FE)	
	Material	Spec	Material	Spec
Casing	Cast Iron	ASTM 148 CL30	Cast Iron	ASTM 148 CL30
Impeller	Cast Iron	ASTM 148 CL20	Silicon Bronze	ASTM B584 C87500
Wear Ring	Cast Iron	ASTM 148 CL20	Bismuth Brass	NA
Seal Housing / Adaptor	Cast Iron	ASTM 148 CL30	Cast Iron	ASTM 148 CL30
Shaft Sleeve	Stainless Steel	AISI Type 300	Stainless Steel	AISI Type 300
Impeller Key	Carbon Steel	A108	Carbon Steel	A108
Impeller Bolt / Nut	Stainless Steel	AISI Type 300	Stainless Steel	AISI Type 300
Impeller Washer	Stainless Steel	AISI Type 300	Stainless Steel	AISI Type 300
Mechanical Seal	316 SS Metal Parts / Carbon Rotating Face / Ceramic Stationary			

Other Irrigation Products (from full line brochure)



GT



3642



HSC



Prime Line® SP

Other Irrigation Products



AquaForce



Turbine



Aquavar CPC



ITT

Ag./Irrigation



Goulds Pumps, Prime Safe, AquaBoost and the ITT Engineered Blocks Symbol are registered trademarks and tradenames of ITT Industries Inc.

SPECIFICATIONS ARE SUBJECT TO CHANGE WITHOUT NOTICE.

BR3656AG March, 2006

© 2006 ITT Water Technology, Inc.

Engineered for life